

ATLAS

INDUSTRIAL LED HIGHBAY



4K/5K/5.7K
CCT Switch



>100,000hrs
@ L70



IP69K
Rating



5 Year
Warranty



190lm/W
Efficacy

- ✓ High output up to 36,000lm @ 200W
- ✓ Long >100,000 hours life
- ✓ High efficacy of up to 190lm/W
- ✓ Finless easy clean design
- ✓ Flexible wattage select options (100W/150W/200W)
- ✓ Wide operating temperatures of -40° to +50°
- ✓ Reduced glare (UGR22 @ 150W)
- ✓ 3CCT selectable (4000k/5000K/5700K)
- ✓ NSF Listed - suitable for food processing and wash-down areas
- ✓ Emergency version
- ✓ Quick connect sensor options



CODE

ATLAS-200-8457-90

WATTAGE/LUMEN OUTPUT @4000K

100W (19,000lm), 150W (27,000lm), 200W (36,000lm)

DIMENSIONS

Ø390x100

WEIGHT

3.6kg

LIGHTING DATA

Light Source	SMD LED
Lifetime	>100,000hrs @L70 B50 87,000hrs @L80 B10 42,000hrs @L90 B10
Luminaire Efficacy	200W = 180lm/W 150W = 180lm/W 100W = 190lm/W
CCT	Selectable 4000K/5000K/5700K
CRI	>80
SDCM	<5
UGR Rating	25(200W) 22(150W) 22(100W)
Beam angle	90°

ELECTRICAL DATA

Mains Voltage	AC100-277V / 50-60 Hz
Power Factor (Typ.)	0.97
THD	<8%
Inrush Current	80A @ 450uS
Surge protection	CM: 6kV,DM: 6kV
Protections	SCP/OTP/OVP/UVP
Driver Lifetime	100,000hrs (Tc≤70°C)
Connection	3m 3 core cable with 3-pin plug
Flicker Free	Yes (PstLM <1 / SVM <0.4)
Options	Emergency (suffix: -EM) 0-10V (suffix: -0-10V) DALI (suffix: -DA)

DESIGN / CONSTRUCTION

Body Material	Aluminium
Lens Material	Polycarbonate
Finish	Epoxy Anti-Corrosion Coating
Colour	Grey
Safety Chain	Included 80cm
Eye Bolt	304 Stainless Steel

TECHNICAL DATA

IP Rating	IP69K
IK Rating	IK10
Operating Temp	-40° to +50°C
Protection Class	Class 1
Hygienic Design	NSF/ANSI 2 Listed (Splash & Non-Food Zone)
NSF Certificate	CO354651
Certifications	SAA, NSF
Warranty	5 Year product replacement

PHOTOMETRIC DIAGRAMS

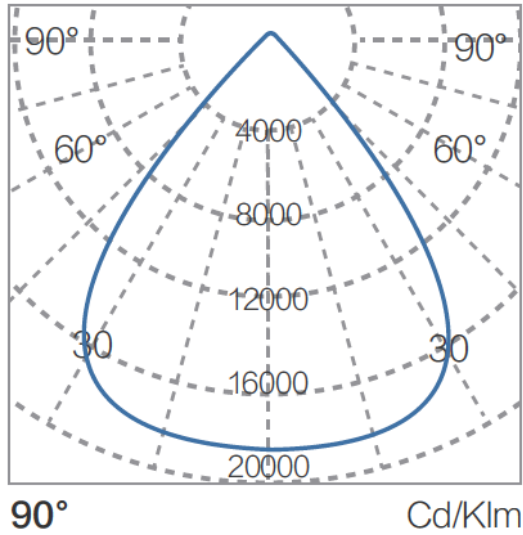

DIMENSIONS

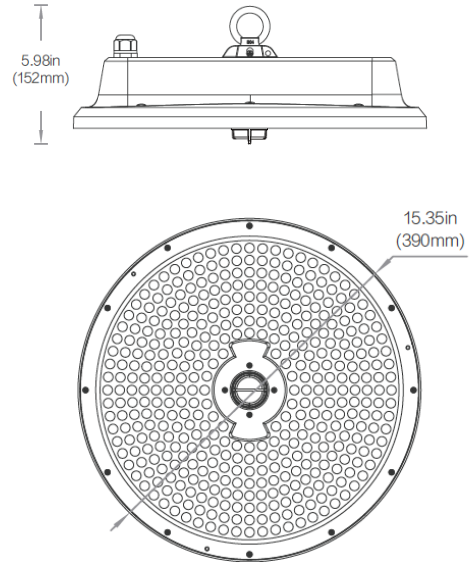

DRIVER SETTINGS



Dip Switch to adjust output power
+ Dip Switch to adjust color temperature

Note: Use dip switch only after mains off.

ACCESSORIES



SURFACE MOUNTING KIT

Material	Polycarbonate
Tiltable	90°
Product Code	ATLAS-SMKIT



POLYCARBONATE REFLECTOR 90D

Material	Polycarbonate
Beam angle	90°
Product Code	ATLAS-PCR90

ORDERING EXAMPLE

ATLAS - 200 - 8457 - 90 - DA

Range	Watt	CRI+CCT	Optic	Control
RANGE	WATT	CRI+CCT	OPTIC	CONTROL
Atlas	200 (200W max)	8457 (CRI80, 4000K, 5000K, 5700K)	90 (90°)	N/A (Fixed - Non dimmable)
				DA (DALI-2 Dimming)
				0-10 (0-10V)

ATLAS

INDUSTRIAL LED HIGHBAY

EVOLVE
LIGHTING

IMAGES

